

**PART LIST**

NO	Description	Specification	Q'ty
1	Base		1
2	Motor base		1
3	Motor	1-1/2HP	1
4	Disc cover		1
5	Aluminum Disc	12"	1
6	Sanding paper	12"	1
7	Aluminum table		1
8	Left tilting turning		1
9	Right tilting turning		1
10	Dust hood cover	2-1/2"	1
11	Left safety guard		1
12	Right safety guard		1
13	Platen		1
14	Cast iron table of platen		1
15	Tilting turning of platen		1
16	Platen packing		1
17	Drive roller		1
18	Idler roller		1
19	Idler roller shaft		1
20	Ball bearing	6201ZZ	2
21	C-type ring	S-12	1
22	Idler roller bracket		1
23	Push spindle		1
24	Fixing spindle		1
25	Push fixing bracket		1
26	Ball bearing cover		1
27	Ball bearing		1
28	Platen table stop		1
29	Platen cover		1
30	Idler roller cover		1
31	Handle		1
32	Fixing plate		1
33	Graphite paper		1
34	Sanding paper	6" x 48"	1
35	Tilting turns spindle		1

36	Switch plate		1
37	Knob		2
38	Pointer		1
39	Round head screw	M4 x 8	7
40	Round head screw	M6 x 8	2
41	Washer	M6	4
42	Hex. head screw	M6 x 10	2
43	Hex. head screw	M6 x 12	6
44	Washer	1/4" x 13	6
45	Nut	M6	6
46	Tilting label sticker	-15 ~45 degree	1
47	Hex. head screw	M8 x 12	6
48	Spring washer	M8	6
49	Hex. head screw	M8 x 25	4
50	Washer	M8 x 18	5
51	Nut	M8	7
52	Hex. head screw	M8 x 16	2
53	Hex. bolt	M8 x 15	1
54	Hex. bolt	M8 x 18	3
55	Hex. bolt	M8 x 20	4
56	Hex. bolt	M8 x 25	1
57	Hex. bolt	M5 x 25	1
58	Hex. bolt	M6 x 25	2
59	Hex. bolt	M6 x 15	3
60	Hex. head screw	M8 x 30	1
61	Pan head screw	M6 x 20	4
62	Pointer		1
63	Set screw	6 x 10	4
64	Push back spring		1
65	Push back spring		1
66	Adjusting screw	M8 x 50	1
67	Nut	M6	2
68	Nut	M10	1
69	Hex. bolt	M6 x 10	4
70	Polygon knob	M6 x 10	2
71	Pentagon knob	M6 x 10	1
72	Knob	M6 x 22	1

73	Miter gage		1
74	Pin	3/16" x 20	1
75	Round head screw	3/16" x 6	1
76	Pointer		1
77	Miter bar		1
78	90 degree sticker	0 ~ 90 degree	1
79	60 degree sticker	-15 ~ 45 degree	1
80	Power cord		1
81	Switch		1
82	Sprain release	6W-4S	3
83	Connector		1
84	Ball bear packing		1
85	Key	6 x 6 x50	1
86	Pointer		1
87	Set Screw	M5 x 10	2
88	Open end wrench	22mm	1
89	Open end wrench	10-13mm	1
90	Hexagon wrench	M6	1
91	Hexagon wrench	M5	1
92	Hexagon wrench	M4	1
93	Round head screw	M5 x 8	4
94	Hex. bolt	M6 x 10	4
95	Temperature control switch		1
96	Washer	6.5 x 16 x 2	1
97	Hex. bolt	M6 x 30	1

### TOOL TABLE

This sturdy 24" tall, universal tool stand measure 23-3/4" x 31-3/4" at the base and 14-1/4" x 22" at the top. Includes non-slip rubber feet. Capacity: 1000LB.

### PART LIST

NO	Description	Specification	Q'ty
1	Leg	618 x 702mm	4
2	Middle support (long)	670.7 x 44.5 x 1.6	2
3	Middle support (short)	465.7 x 44.5 x 1.6	2
4	Screw	5/16" x 1/2"	36
5	Nut	5/16"	36
6	Foot pad	55 x 55 x 12	4

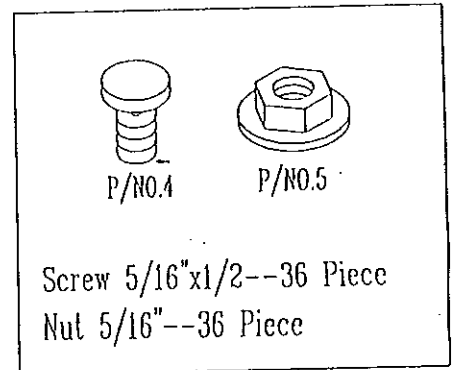

Screw for middle support

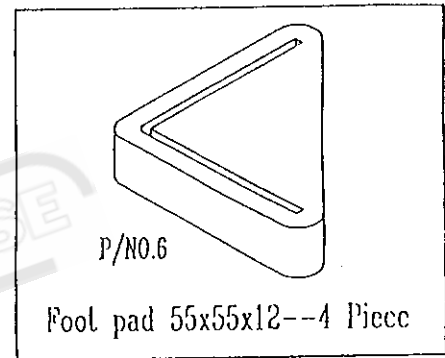

Foot pad for legs

